

SOLARTECH POWER

SPM008P/010P

SPECIFICATIONS

CELL	Multicrystalline silicon solar cell 78mmx26mm	
No. of cells and connections	36(4x9)	
Dimension of module	350x300x25(mm)	13.8x11.8x0.98(in)
Weight	1.4kg	3.11b

Characteristics

Model	SPM008P	SPM010P
Power at STC(Pm)	8W	10W
Maximum power voltage(Vpm)	17.1V	17.3V
Maximum power current(Ipm)	0.46A	0.59A
Open circuit voltage(Voc)	21.0V	21.8V
Short circuit current(Isc)	0.61A	0.64A
Tolerance	± 5%	± 5%
Module efficiency	7.6%	9.5%

STC: Temperature 25°C, Irradiance 1000W/m², AM=1.5

Limits

Operating temperature	-40 to +85°C
Maximum system voltage	600V DC
Series fuse rating	10A

Components & Mechanical Data

Front Glass	3.2mm tempered
Junction Box	IP-65 rated
Frame	Anodized aluminum alloy type 6063-T5
Encapsulation Material	EVA(0.5±0.05mm thickness)
Back Foil	White PET(0.2±0.03mm thickness)
Temperature Range	-40°C to +90°C
Max Load	5400Pa

Temperature coefficient

Nominal Operation Cell Temperature	48°C±2°C
Current temperature coefficient	0.06±0.01 %/K
Voltage temperature coefficient	-(78±10) mv/k
Power temperature coefficient	-(0.5±0.05) %/k

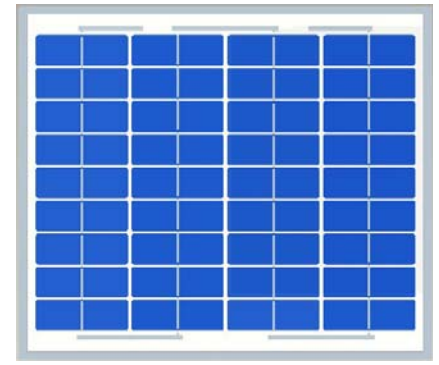

Back of the module

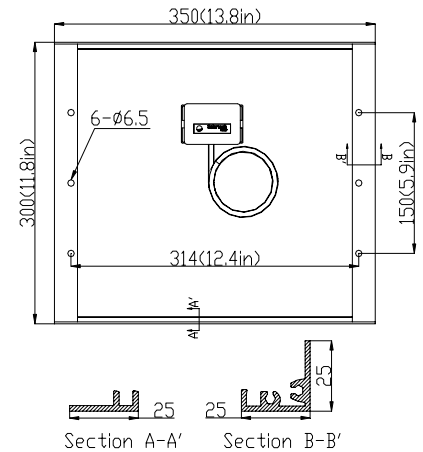

IV CURVES

