

SOLARTECH POWER

SPM100P/110P

SPECIFICATIONS

CELL	Multicrystalline silicon solar cell	156mmx156mm
No. of cells and connections	36(4x9)	
Dimension of module	1482x676x50(mm)	58.3x26.6x1.97(in)
Weight	12kg	26.51b

Characteristics

Model	SPM110P	SPM100P
Power at STC(Pm)	100W	110W
Maximum power voltage(Vpm)	16.4V	17.1V
Maximum power current(Ipm)	6.22A	6.54A
Open circuit voltage(Voc)	18.4V	21.2V
Short circuit current(Isc)	7.19A	7.43A
Tolerance	± 5%	± 5%
Module efficiency	9.98%	10.97%

STC: Temperature 25°C, Irradiance 1000W/m², AM=1.5

Limits

Operating temperature	-40 to +85°C
Maximum system voltage	1000V DC
Series fuse rating	12A

Components & Mechanical Data

Front Glass	3.2mm tempered
Junction Box	IP-65 rated
Frame	Anodized aluminum alloy type 6063-T5
Encapsulation Material	EVA(0.5±0.05mm thickness)
Back Foil	White TPT(0.32±0.03mm thickness)
Temperature Range	-40°C to +90°C
Max Load	5400Pa

Temperature coefficient

Nominal Operation Cell Temperature	48°C±2°C
Current temperature coefficient	0.06±0.01 %/K
Voltage temperature coefficient	-(78±10) mv/k
Power temperature coefficient	-(0.5±0.05) %/k

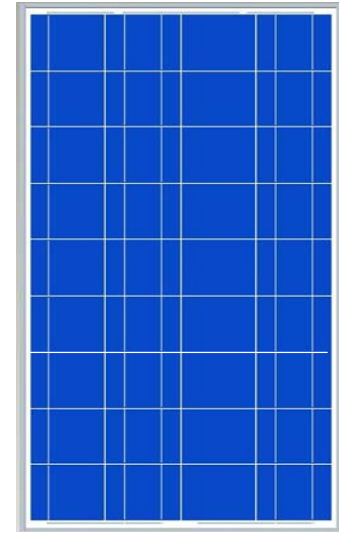

Back of the module

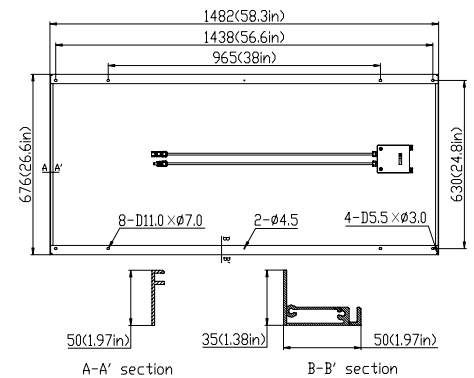

IV CURVES

